



SERIES NE□ 2" - 12"  
SERIES NF□ 14" - 24"

# BUTTERFLY VALVE

[www.trueline.ca](http://www.trueline.ca)

# NE & NF SERIES

Trueline has developed a line of high quality reliable butterfly valves. Easy maintenance and component interchange means lower installed cost and years of service life from our proven design. The NE & NF series are well suited to a host of today's industrial services.

## Component characteristics

### A) Body

The one piece body is available in a wafer, lug or flanged style. These series feature a 2" longer neck to accommodate piping insulation. The wafer version features a raised locating ring around the body's periphery which serves to align the valve correctly between the mating flanges. The body strength, as projected in the Finite Element Analysis, has been designed to provide to withstand forces far exceeding their rated pressure and piping loads.

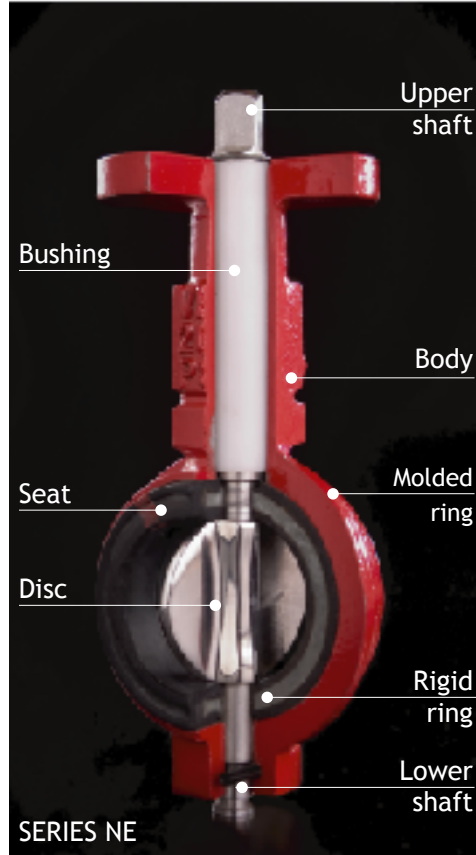

### B) Disc

The thin profile of the disc has been designed to provide the optimum flow in all opening positions. The polishing profile provides low cycling torques and uniform sealing while minimizing cycling wear. Particularly important for high cycle applications.

The disc is also available in (optional) HT-65 & HT-2200 hardening infusions. Consult factory for details.

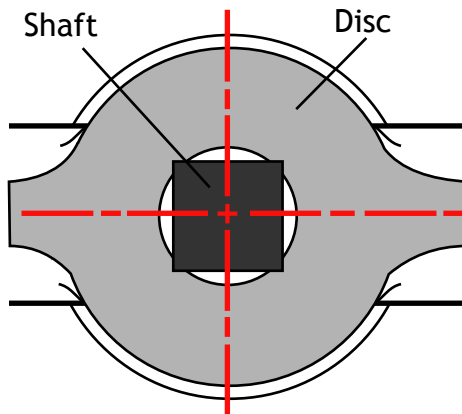

### C) Shaft

The upper shaft transfers motion to the disc by a square drive. This proven design eliminates a through shaft and screws while ensuring a positive engagement disc to shaft connection. The out-board end of the shaft readily connects for direct mounting of any number of actuation options. The lower shaft is fixed within the body by means of a roll pin. Together the "Trunnion" assembly guarantees a perfect alignment between body, disc and shaft.

### D) Interchangeable Seat

Completely encapsulating the body, the vulcanized elastomer with rigid ring prevents seat 'flex' which often leads to seat leakage in conventional valves. There are three primary sealing locations.

- 1 - Sealing between the installation flange and the body of the valve accomplished through a molded in O'Ring on the sidewall.
- 2 - Interference sealing between the disc and seat.
- 3 - Sealing of the stem with semi-O'Ring in the chamfer of the upper and lower shaft.

### E) Bushing

The polypropylene bushing eliminates seizure between the body and shaft, resulting in lower torques and leakage due to torsional deflection.

## Design standards

### Construction

- ::□Face to face
- API609 Category A
- ISO 5752 Column 20
- MSS-SP67

### Test

- API598
- ASME/ANSI B16.34
- MSS-SP68

- ::□Coupling of the top plate
- ISO 5211/DIN3337

### Seat Bushing

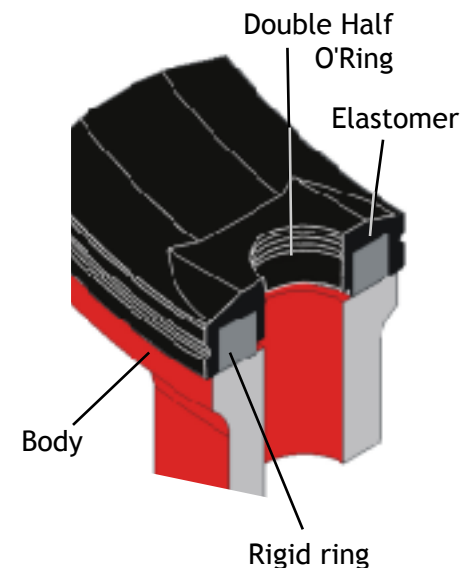

# Trueline Sealing System - Greater Durability

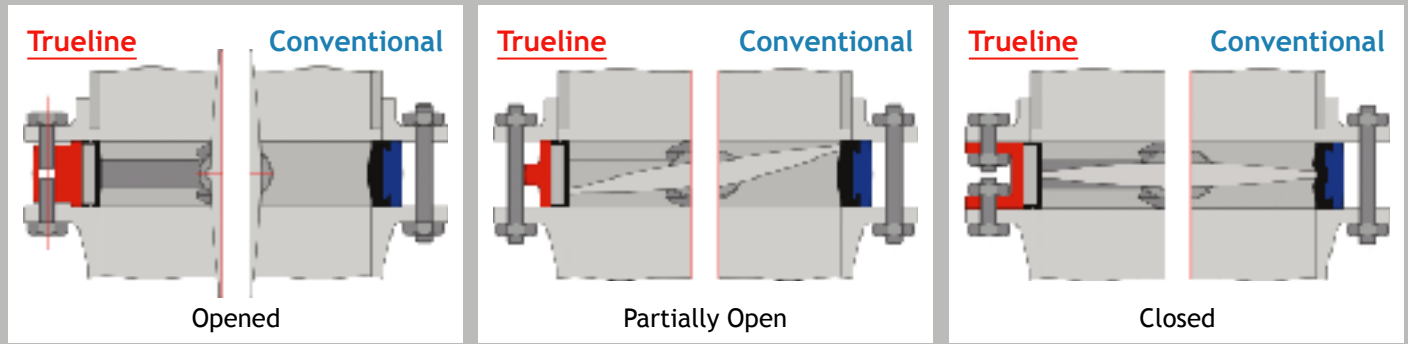

## Trueline advantages

- :: Minimized elastomer contact prevents the seal from distorting, which eliminates wear and leakage.
- :: Integral rigid ring eliminates seat distortion. Valve may be installed in the fully closed position.
- :: Molded in O'Ring on seat sidewall eliminates the need for flange gaskets when used with ANSI flanges.

## Disadvantages of the conventional seats

- :: High concentration of elastomer mass in the sealing process; greater opportunity for deformation and seat tearing.
- :: Greater possibility to bulge through fluid absorption, causing excessive torque increases.
- :: Opening torques may be directly affected by incorrect installation, resulting in reduced seat life.

## Flange Requirements

Trueline Valves are intended for installation between flanges according to ASME/ANSI 125/150, DIN PN10/16, NBR 7675 PN 10/16, JIS PN10. Although weld neck flanges are recommended, Trueline allows installation between slip on flanges without de-rating the pressure rating, providing the valve is correctly aligned. For dead end service with downstream flange removed, use weld neck or socket weld flanges only.

## End of Line Applications

MAXIMUM PRESSURE	CONDITIONS
150 psi (10 Bar)	Valve fixed between two flanges
75 psi (5 Bar)	Valve fixed in one of the flanges

## Pressure Ratings

Trueline NE & NF series have 3 pressure ratings for valves 2" through 12" and 14" through 24".

## "Cold Working Pressure" (CWP)

PRESSURE (psi)	PRESSURE (bar)
50	3.5
150	10
250	17.5

Lower pressure ratings offer lower torques resulting in smaller actuator requirements.

Maximum line velocities are 9 m/sec for fluids and 54 m/sec for gases.

## Speed limits for ON-OFF services

Fluid	9 m/s 29.53 ft/s
Gases	54 m/s 177.17 ft/s

## Finite Element Analysis

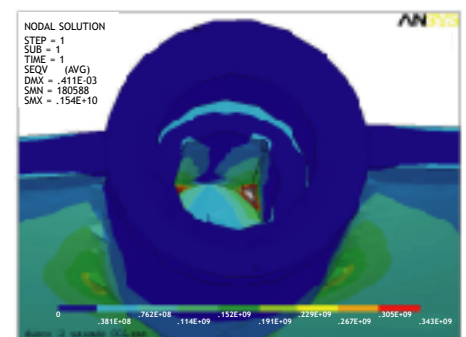
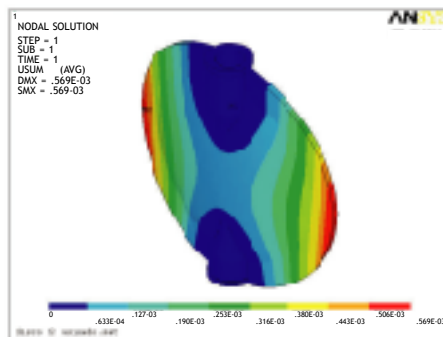
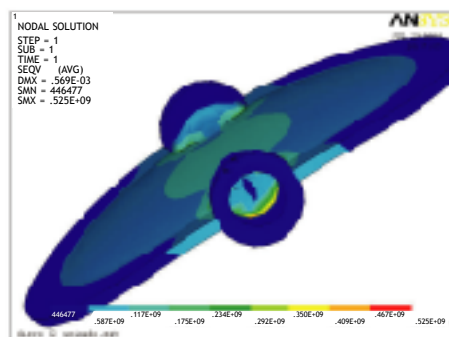

# SERIES NE

## Dimensions

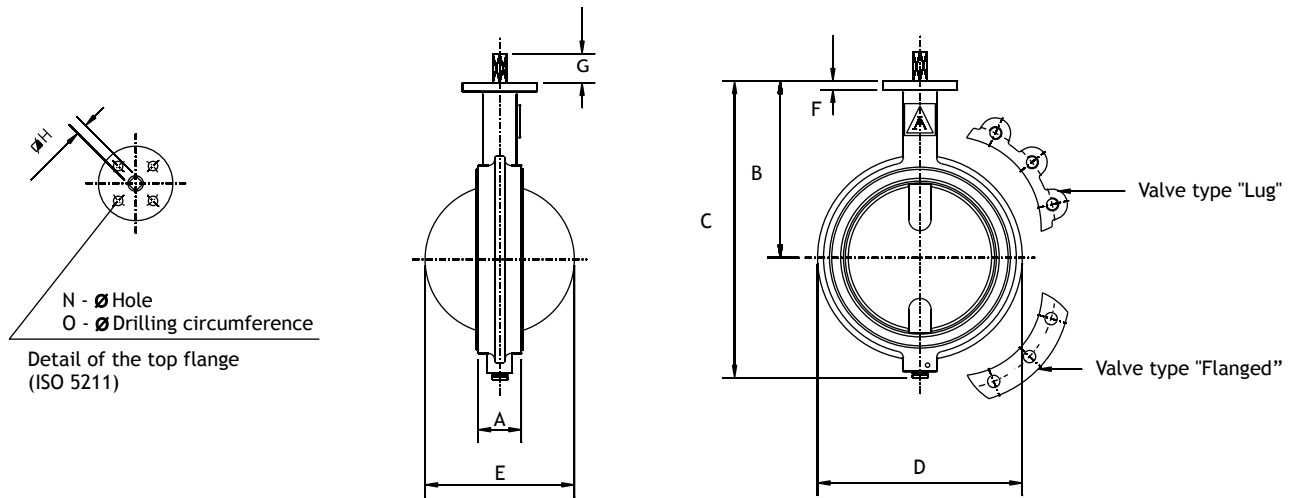

VALVE		2"	2 1/2"	3"	4"	5"	6"	8"	10"	12"		
DIMENSIONS	A	mm in	44.00 1.73	47.00 1.85	53.50 2.11	57.00 2.24	63.00 2.48	71.00 2.80	81.00 3.19			
	B	mm in	142.90 5.63	155.60 6.13	161.90 6.37	181.00 7.13	196.90 7.75	209.60 8.25	239.70 9.44	285.80 11.25	309.60 12.19	
	C	mm in	216.20 8.51	235.20 9.26	247.80 9.76	281.10 11.07	309.50 12.19	334.30 13.16	397.10 15.63	475.90 18.74	551.70 21.72	
	D	mm in	101.60 4.00	120.70 4.75	133.40 5.25	171.50 6.75	193.70 7.63	219.10 8.63	276.20 10.87	336.60 13.25	406.40 16.00	
	E	mm in	58.30 2.30	72.50 2.85	84.70 3.33	106.60 4.20	129.80 5.11	153.90 6.06	199.40 7.85	248.20 9.77	300.00 11.81	
	F	mm in	12.20 2.30									
	G	mm in	15.00 0.59			20.00 0.79			25.00 0.98			
	H (DIN 3337)	mm in	$\varnothing$ 14 $\varnothing$ 0.55			$\varnothing$ 17 $\varnothing$ 0.67			$\varnothing$ 22 $\varnothing$ 0.86			
	N	mm in	$\varnothing$ 7/9 $\varnothing$ 0.28/0.35			$\varnothing$ 9 $\varnothing$ 0.35			$\varnothing$ 9/11 $\varnothing$ 0.35/0.43			$\varnothing$ 11 $\varnothing$ 0.43
	O	mm in	$\varnothing$ 50/70 $\varnothing$ 1.92/2.76			$\varnothing$ 70 $\varnothing$ 2.76			$\varnothing$ 70/102 $\varnothing$ 2.76/4.02			$\varnothing$ 102 $\varnothing$ 4.02
ISO5211		F05/F07			F07			F07/F10		F10		

Note: Flanged Valve follows dimensional API609A table 1. Manufactured starting from 6".

Table: CV\* Flow Coefficient - NE Series

% OF OPENING	NOMINAL DIAMETER OF THE VALVE									
	2"	2 1/2"	3"	4"	5"	6"	8"	10"	12"	
90	130	200	300	550	1125	1950	3250	5000	7500	
80	105	160	240	475	1000	1650	2725	4300	6050	
75	90	130	205	400	830	1350	2200	3600	5000	
70	70	105	160	305	625	1030	1750	2750	4050	
60	53	83	125	235	490	800	1300	2150	3100	
50	27	42	63	120	250	410	700	1150	1600	
40	17	26	38	73	155	250	420	670	1000	
30	9	15	22	42	88	145	250	390	550	
25	6	10	15	28	60	98	170	260	380	

\*CVs based on water at an Sp.Gr.1.

## SERIES NE

### Weight Table

VALVE	NOMINAL DIAMETER OF THE VALVE									
	2"	2 1/2"	3"	4"	5"	6"	8"	10"	12"	
Wafer	lb	5.51	8.75	9.44	11.46	14.99	19.62	28.22	44.09	74.74
	kg	2.50	3.97	4.28	5.20	6.80	8.90	12.80	20.00	33.90
Lug	lb	6.61	9.92	11.02	16.53	24.25	28.66	40.79	63.93	95.90
	kg	3.00	4.50	5.00	7.50	11.00	13.00	18.50	29.00	43.50
Flanged	lb	-	-	-	-	-	34.83	56.88	83.33	129.19
	kg	-	-	-	-	-	15.80	25.80	37.80	58.60

### Exploded View

ITEM	DESCRIPTION
1A	Wafer Body
1B	Lug Body
1C	Flanged Body
2	Seat
3	Disc
4	Upper Shaft* ASTM A 276 Type 410
5	Bushing* Polypropilene
6	Lower Shaft* ASTM A 276 Type 410
7	Roll Pin Spring Steel

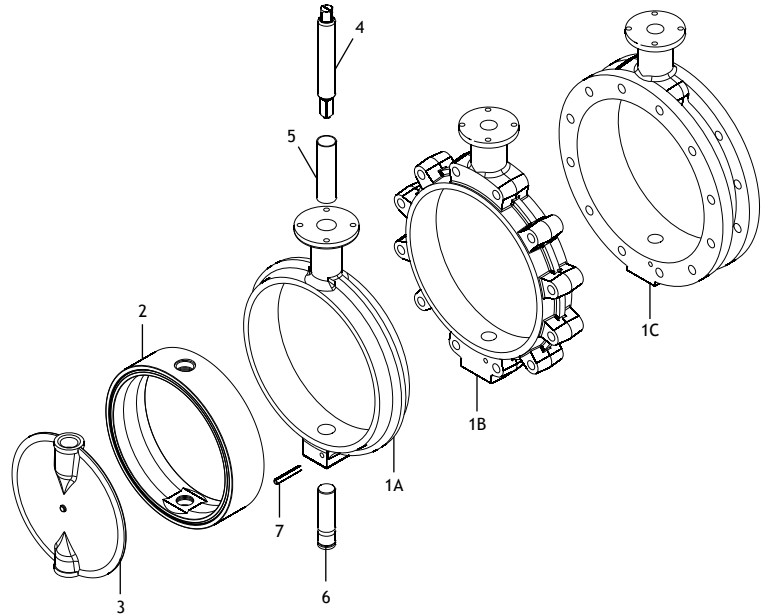

\* For 250 psi, bushing in bronze and superior stem with thermal treatment for  $\varnothing = 8"$ .

### Materials Selection

MODEL	WORKING PRESSURE	DIAMETER NOMINAL	BODY MATERIAL	DISC MATERIAL	SEAT MATERIAL	CONSTRUCTION	DRILLING	ACTUATION
NE	1 -50 psi	1 - 2"	0 - Special	0 - Special	0 - Special	1 - Wafer	0 - Special	0 - Special
	2 -150 psi	2 - 2 1/2"	1 - Carbon Steel ASTM A-216WCB	1 - Stainless Steel ASTM A-351 CF8-M	1 - NBR(Buna-N)	2 - Lug	1 - ASME ANSI 150	1 - Bare Shaft
	3 -250 psi	3 - 3"	2 - Stainless Steel ASTM A-351 CF8-M	2 - Polished Stainless Steel ASTM A-351 CF8-M	2 - Neoprene	3 - Flanged	2 - DIN EN 1092-1 PN10/PN16	2 - Gear Operator
		4 - 4"	3 - Ductile Iron ASTM A-536 65-45-12	3 - Ductile Cast Iron ASTM A-536 65-45-12	3 - EPDM			3 - Pneumatic Actuator
		5 - 5"	4 - Cast Iron ASTM A 126 CLB	5 - Ductile Iron ASTM A-536 65-45-12 Nickel Plated	4 - Hypalon			4 - Hydraulic Actuator
		6 - 6"		6 - Aluminum Bronze ASTM B148 9D	5 - Viton			5 - Electric Actuator
		7 - 8"		7 - Stainless Steel ASTM A-351 CF8-M Rev. E-CTFE*	6 - Buna GA-1	8 - SBR		6 - Position Lever Handle
		8 - 10"		8 - Stainless Steel ASTM A-351 CF8-M - Nickel-plated	9 - Carboxylic Nitrilic			7 - Float Actuation
		9 - 12"		9 - Stainless Steel ASTM A-351 CF8				8 - Stem Extension

### Torque Table (lb/in)\*

CPW (psi)	NOMINAL DIAMETER OF THE VALVE									
	2"	2 1/2"	3"	4"	5"	6"	8"	10"	12"	
250	221	327	513	761	1194	1531	2549	4124	7000	
150	106	106	194	265	451	548	1000	1796	3000	
50	70	70	88	106	141	177	354	699	1159	

\* Torque values are based on non-compressible fluid (water) – no safety factor included.

# SERIES NF

## Dimensions

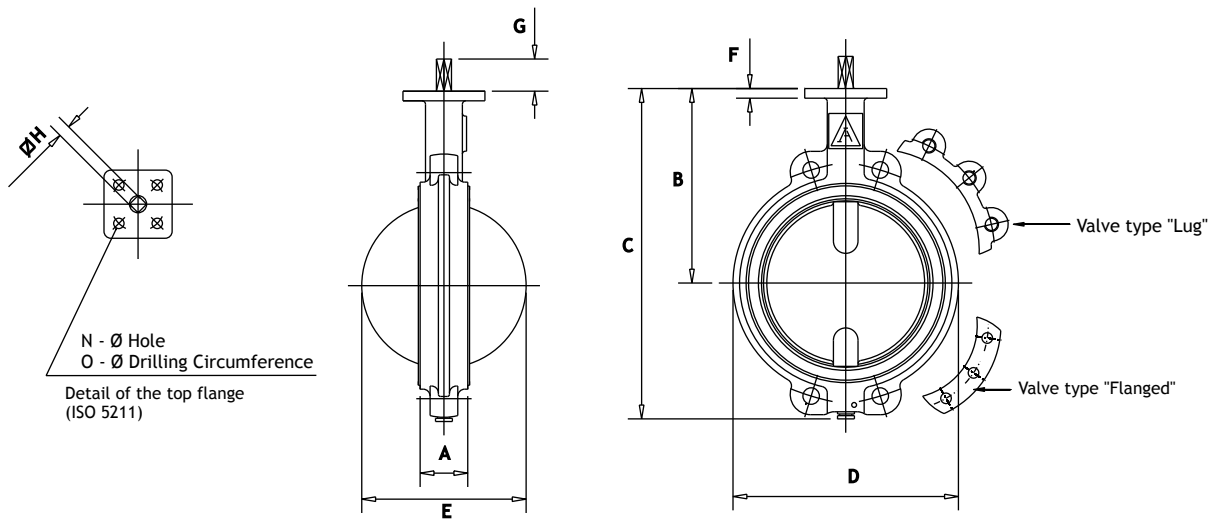

VALVE		14"	16"	18"	20"	24"	
DIMENSIONS	A	mm in	76.50 3.01	99.00 3.90	112.00 4.41	124.50 4.90	152.00 5.98
	B	mm in	350.00 13.78	374.70 14.75	401.60 15.81	427.00 16.81	490.50 19.31
	C	mm in	641.30 25.25	676.30 26.63	743.00 29.25	793.80 31.25	914.40 36.00
	D	mm in	431.80 17.00	485.80 19.13	546.10 21.50	603.30 23.75	717.60 28.25
	E	mm in	335.80 13.22	381.70 15.03	436.00 17.17	486.80 19.17	593.40 23.36
	F	mm in			22.20 0.87		
	G	mm in		30.70 1.21		39.70 1.56	49.30 1.94
	H (DIN 3337)	mm in		$\varnothing$ 27 $\varnothing$ 1.06		$\varnothing$ 36 $\varnothing$ 1.42	$\varnothing$ 46 $\varnothing$ 1.81
	N	mm in		$\varnothing$ 13 $\varnothing$ 0.51		$\varnothing$ 17 $\varnothing$ 0.67	$\varnothing$ 23 $\varnothing$ 0.91
	O	mm in		$\varnothing$ 125 $\varnothing$ 4.92		$\varnothing$ 140 $\varnothing$ 5.51	$\varnothing$ 165 $\varnothing$ 6.50
ISO5211			F12		F14	F16	

Note: Flanged valve, follows dimensional API609A prices 1.

Table: CV\* Flow Coefficient - NF Series

% OF OPENING	NOMINAL DIAMETER OF THE VALVE				
	14"	16"	18"	20"	24"
90	10.000	12.500	17.500	22.000	28.000
80	8.100	10.800	14.000	17.500	24.000
75	6.700	9.000	12.000	15.000	20.500
70	5.100	6.500	9.200	11.500	16.500
60	4.100	5.100	7.100	8.700	11.750
50	2.200	2.650	3.700	4.600	6.100
40	1.300	1.700	2.300	2.800	3.800
30	750	900	1.250	1.600	2.200
25	500	650	900	1.125	1.500

\*Orientation values, for specific weight of the water = 1.0 at 20°C.

# SERIES NF

## Weight Table

VALVE	NOMINAL DIAMETER OF THE VALVE					
	14"	16"	18"	20"	24"	
Wafer	lb	112.44	158.73	205.03	246.92	374.79
	kg	51.00	72.00	93.00	112.00	170.00
Lug	lb	132.28	202.83	240.30	332.90	540.13
	kg	60.00	92.00	109.00	151.00	245.00
Flanged	lb	182.98	227.08	286.60	407.85	540.13
	kg	83.00	103.00	130.00	185.00	245.00

## Exploded View

ITEM	DESCRIPTION
1A	Wafer Body
1B	Lug Body
1C	Flanged Body
2	Seat
3	Disc
4	Upper Shaft* ASTM A 276 Type 410
5	Lower Shaft ASTM A 276 Type 410
6	Elastic Pin Spring Steel
7	Lower Bushing Copper
8	Upper Bushing Copper
9	Retention Bushing Copper

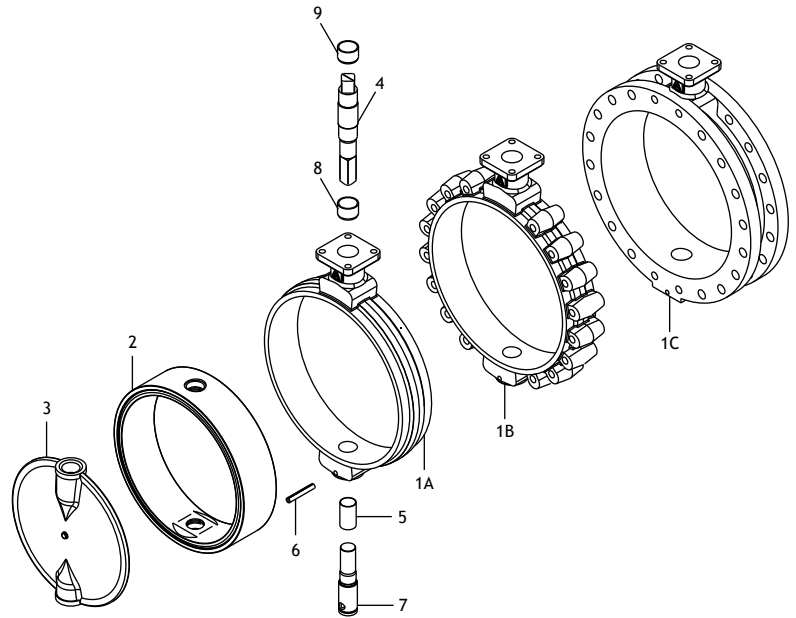

\* For 250 psi, upper shaft is heat treated.

## Materials Selection

MODEL	WORKING PRESSURE	DIAMETER NOMINAL	BODY MATERIAL	DISC MATERIAL	SEAT MATERIAL	CONSTRUCTION	DRILLING	ACTUATION	
NF	1 -50 psi	1 - 14"	0 - Special	0 - Special	0 - Special	1 - Wafer	0 - Special	0 - Special	
	2 -150 psi	2 - 16"	1 - Carbon Steel ASTM A-216WCB	1 - Stainless Steel ASTM A-351 CF8-M (polished)	1 - NBR (Buna-N)	2 - Lug	1 - ASME ANSI 150	1 - Bare Shaft	
	3 -250 psi	3 - 18"	2 - Stainless Steel ASTM A-351 CF8-M	2 - Polished Stainless Steel ASTM A-351 CF8-M	2 - Neoprene	3 - Flanged	2 - DIN EN 1092-1 PN10/PN16	2 - Gear Operator	
		4 - 20"	3 - Ductile Iron ASTM A-536 65-45-12	3 - Ductile Iron ASTM A-536 65-45-12	3 - EPDM			3 - Pneumatic Actuator	
		5 - 24"	4 - Cast Iron ASTM A-126 CLB	5 - Ductile Iron ASTM A-536 65-45-12 Nickel plated	5 - Ductile Iron ASTM A-536 65-45-12 Nickel plated	4 - Hypalon			4 - Hydraulic Actuator
				6 - Aluminum Bronze ASTM B148 9D	6 - Aluminum Bronze ASTM B148 9D	5 - Viton			5 - Electric Actuator
				7 - Stainless Steel ASTM A-351 CF8M Rev. E-CTFE*	7 - Stainless Steel ASTM A-351 CF8M Rev. E-CTFE*	6 - Buna GA-1			6 - Electric Actuator
				8 - Stainless Steel ASTM A-351 CF8M Nickel plated	8 - Stainless Steel ASTM A-351 CF8M Nickel plated	8 - SBR			7 - Float Actuation
				9 - Stainless Steel ASTM A-351 CF8	9 - Stainless Steel ASTM A-351 CF8	9 - Carboxylic Nitrilic			8 - Stem Extension

\* For coated disc E-CTFE, pressure of service of 100 psi (7 Bar).

## Torque Table (lb/in)\*

CPW (psi)	NOMINAL DIAMETER OF THE VALVE				
	14"	16"	18"	20"	24"
250 psi	13152	17506	21507	26605	50006
150 psi	4505	6505	8408	10797	19648
50 psi	1663	2796	3398	5000	8408

\* Torque values are based on non-compressible fluid (water)—no safety factor included.

# Valve Types

## SERIES NE



On-off



Control



Electric

## SERIES NF



Wafer



Lug



Flanged

### Actuation

- ::Lever Lock Handle
- ::Manual Gear Operator
- ::Emergency GearBox
- ::Single and Double Acting Pneumatic Actuator
- ::Electric Actuator
- ::Hydraulic Actuator

### Accessories

- ::Solenoid Valve
- ::Limit Switch (all types)
- ::Positioners (pneumatic or Electro pneumatic)
- ::Speed Controls
- ::Filter Regulator
- ::Stem Extensions
- ::Beacon Style Indicator
- ::Locking Device
- ::Babbit Sprocket and Chainwheel
- ::Float Actuator



Distributor / Sales Representative:



Trueline Distribution Inc.  
20201 Clark Graham  
Baie d'Urfé (Québec) H9X 3T5  
T: 514.457.5777 F: 514.457.6169  
Toll free: 1.800.667.4819

[www.trueline.ca](http://www.trueline.ca)

Revision: BV\_NE\_NF\_08/06